

User Guide

Mounting Blocks | MBRUE

V-TRAK

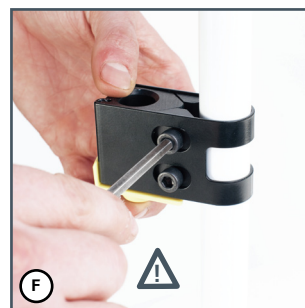
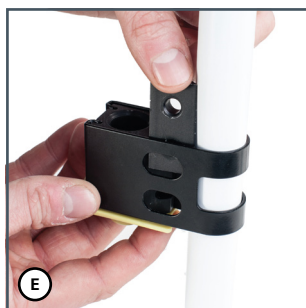
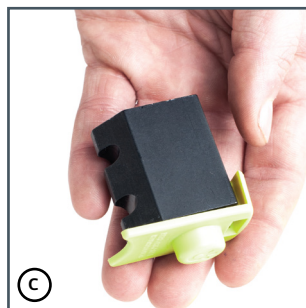
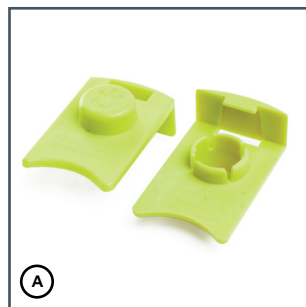
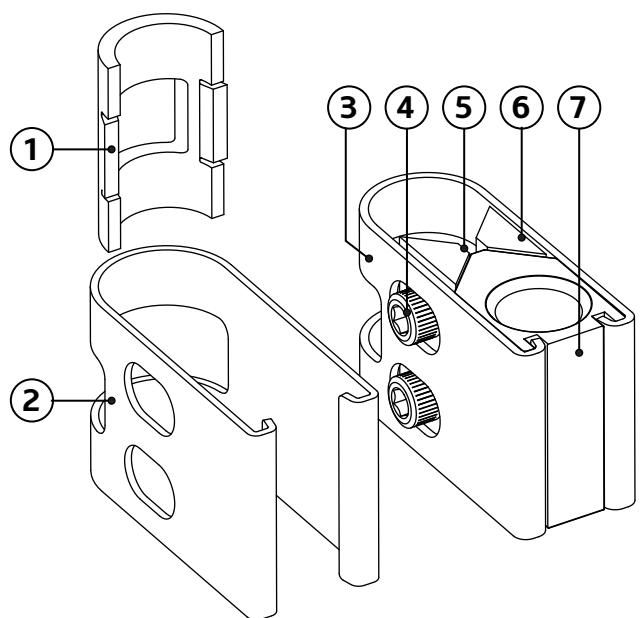
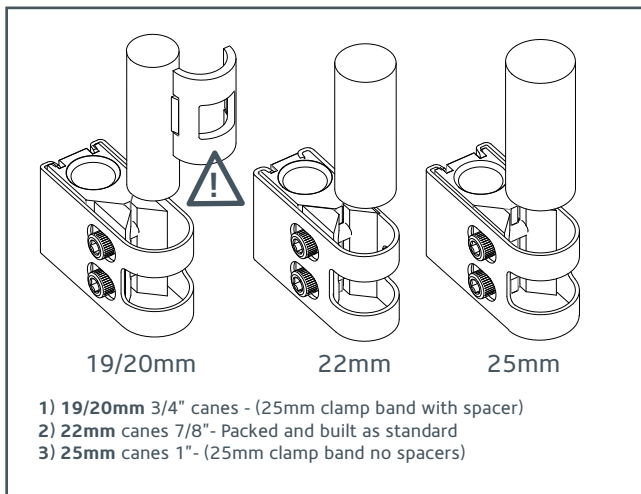

UNIVERSAL MOUNTING BLOCK - MBR UE

- 1 2 x Spacers - For use with 25mm clampband on 19/20mm canes
- 2 2 x 25mm (1Inch) diameter clampbands for 25mm canes
- 3 2 x Clamp bands for 22mm canes (supplied preassembled)
- 4 4 x Clamping screws
- 5 2 x Plain wedges
- 6 2 x Threaded wedges
- 7 2 x Pin blocks

A. The new mounting block clip, aids assembly of the mounting block and comes as standard with clamp bands mounting blocks.

B. In the MBR UE package the preassembled 22mm blocks should be sufficient for most cases. Occasionally it may be necessary to use the additional clamp bands with the spacer for 19 mm canes or without for 25mm canes. Disassemble the mounting block before fitting.

C. Take the pin block and attach the mounting block clip.

D. Attach the clamp band around the cane, using the specific spacer depending on the cane size (keep access screw holes facing outwards for easy adjustment). Slide the pin block (with clip) on to the clamp band that is around the cane

E. Place the wedges into the clamp band. The wedge (Part 5) contacting the clamp band holes should have the larger unthreaded holes and the rear wedge (Part 6), threaded holes.

F. The mounting block clip will keep all parts together. Screw in the clamping screws and tighten with 5mm Allen key. Once attached the mounting block can be moved on the cane to adjust height and angle.

G. When desired height and position is achieved tighten screws (please see user manual for torque settings). The mounting block clip can be left on the mounting block or it can be removed for tightening of the hardware pins and used again for other mounting blocks.

PLEASE NOTE

- SPACERS SHOULD BE PLACED OUTWARDS FROM THE CANE
- Once you are happy with all positioning elements. **PLEASE TIGHTEN ALL SCREWS FOR SAFETY AND SECURITY**
- Please note Mounting blocks are normally installed to the rear of the wheelchair canes and angled inwards to align with the V-Trak arms. They can also be mounted in front of the wheelchair canes but if so make sure the clamping screws remain accessible for final adjustment and tightening.



PERFORMANCE HEALTH PRODUCTS LTD
 UNIT 1, WESTSIDE CAMBRIAN INDUSTRIAL ESTATE, COEDCAE LANE, PONTYCLUN, WALES CF72 9EX
 TEL +44 (0)1443 236 530 | FAX +44 (0)1443 239 355 | INFO@V-TRAK.COM | WWW.V-TRAK.COM

These instructions are intended to be a guide only and should not be used as a substitute for professional judgment. If there are any queries or any uncertainties please call us (01443 236 530) or email us info@v-trak.com for technical advice. Document Number: IFU MBRUE V4.0

