

User Guide

Etac Mounting Blocks | MBETAC

V-TRAK

Etac Mounting block - MB-ETAC SOLD AS A PAIR

- 1 2 x mounting block screws - 5mm Allen key
- 2 1 x mounting block
- 3 2 x locking strip screws - 4mm Allen key
- 4 1x Angled Fixing bracket
- 5 **Locking strip** to fit in channel

1 Loosen the screws enough so that you can slot the locking strip along with the Angled bracket into the rear of the ETAC cane. (examples below)

! Make sure locking strip is is connected to Angle bracket to prevent loss in the cane channel

2 The mounting block can then be attached with the mounting block screws to the Angled fixing bracket in any of the desired positions below.

3 Once in position please make sure the mounting blocks are positioned level and at the same height to aid simple removal of V-Trak hardware.

4 Tighten all screws once in desired position

! Please note : Mounting block has not been crash tested in current format

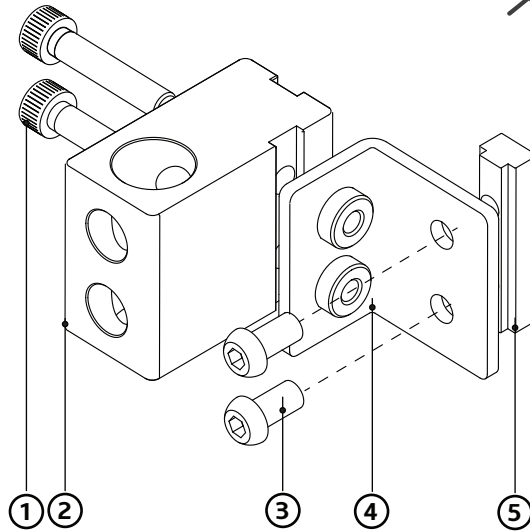

User Guide

Etac Mounting Blocks | MBETAC

V-TRAK

Etac Mounting block - MB-ETAC SOLD AS A PAIR

- 1 2 x mounting block screws - 5mm Allen key
- 2 1 x mounting block
- 3 2 x locking strip screws - 4mm Allen key
- 4 1x Angled Fixing bracket
- 5 **Locking strip** to fit in channel

1 Loosen the screws enough so that you can slot the locking strip along with the Angled bracket into the rear of the ETAC cane. (examples below)

! Make sure locking strip is is connected to Angle bracket to prevent loss in the cane channel

2 The mounting block can then be attached with the mounting block screws to the Angled fixing bracket in any of the desired positions below.

3 Once in position please make sure the mounting blocks are positioned level and at the same height to aid simple removal of V-Trak hardware.

4 Tighten all screws once in desired position

! Please note : Mounting block has not been crash tested in current format

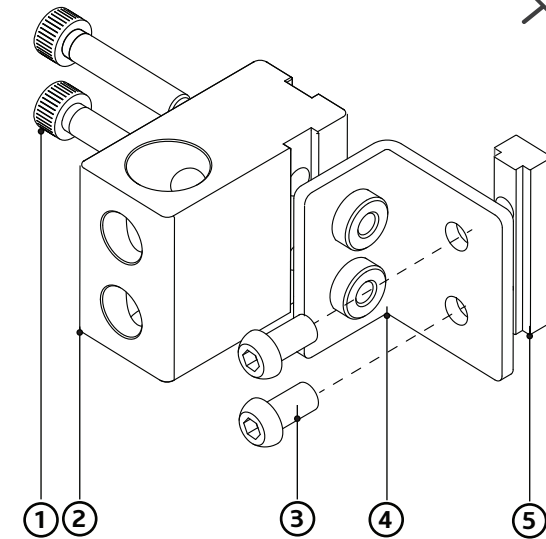

Etac Mounting block - Positioning options on canes

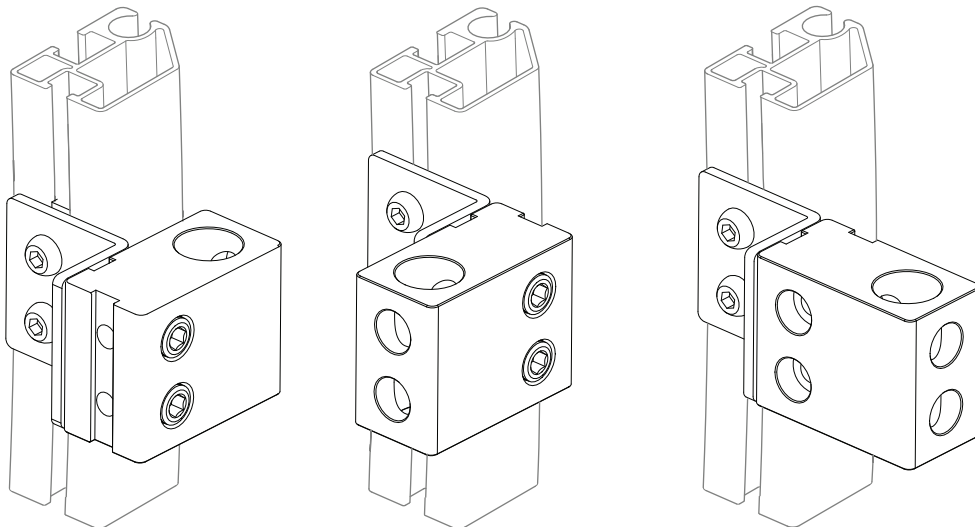

Etac Mounting block - Positioning options on canes

